



Term of Reference

Procurement of Hand Washing Station for City of Yogyakarta

No	Product Name	QTY (unit)	Notes
1	Hand Washing Station (material, installation)	52	- Price include delivery cost and tax

Background

The goods listed in this term of reference is/are required to support the ACTION Project – Active Citizens Building Solidarity and Resilience in Response to COVID-19. The project's main objectives is to enhance poor and marginalised community resilience and solidarity in responding to the impacts of pandemics. The project is implemented by a consortium where Hivos as the coordinator to lead other members consisting of 5 national NGOs, namely : SAPDA, KAPAL Perempuan, CISDI, PUPUK, and PAMFLET.

This project targets marginalized and high-risk populations in rural and urban areas in two phases. Phase one focuses on activities response, such as health care, and water and sanitation systems. Phase two addresses the social and economic recovery phase. The project will be implemented in 5 provinces in Indonesia, which included Jakarta, South Sulawesi, Yogyakarta, West Nusa Tenggara, and West Java. The duration of ACTION is in 24 months.

The distribution of Hand Washing Station is related to the Outcome I: Community-based emergency health responses amplified, and coordination with government initiatives improved

Eligibility

This procurement request is on equal terms for all legally-constituted companies that can provide the requested products and have legal capacity to deliver in Indonesia. Tenderers must state their nationality in their tenders and provide the usual proof of nationality under their national legislation.

Tenderers are requested to state the origin of the goods, and the selected contractor will have to prove the origins of the goods. Exceptions shall be made where goods may originate from any country, in which case no certificate of origins needs to be submitted.

In this specific quotation, tenderers located in the delivery area are preferables to ensure the safety measure and schedule of the delivery.



This project is funded by
the European Union



Principles

The contract shall be awarded to the tender offering best value for money (i.e. the tender offering the best price-quality ratio).

Details

Based on this listed requirement:

No	Provinsi	Kab/Kota	Kecamatan	Kelurahan	QTY
1	DI Yogyakarta	Yogyakarta	Kecamatan Kota Gede	Kelurahan Rejowinangun	8
2			Kecamatan Kota Gede	Kelurahan Pringgan	8
3			Kecamatan Kota Gede	Kel Purbayan	8
4			Kecamatan Jetis	Kelurahan Bumijo	7
5			Kecamatan Jetis	Kelurahan Cokrodingrat	7
6			Kecamatan Wirobrajan	Kelurahan Wirobrajan	7
7			Kecamatan Wirobrajan	Kelurahan Patangpuluhan	7
TOTAL					52

Design Reference:



This project is funded by
the European Union

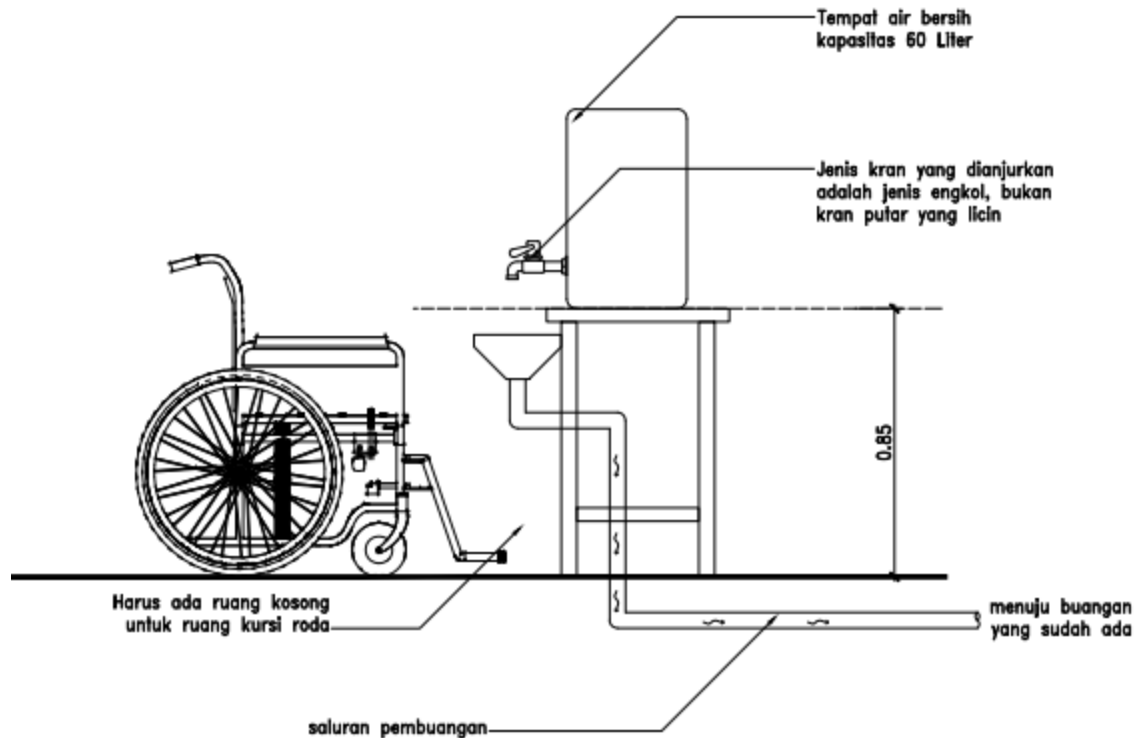

Content of Quotation

Quotations should be submitted in a single e-mail and must contain:

- Description of the item/s requested
- Price quotation inclusive of tax
- Delivery method and Expected Time of Arrival
- Payment terms

Instructions for Submission

Quotations have to be sent by e-mail to: Ms Catharina Utami cutami@hivos.org and Ms Annissa Maulani amaulani@hivos.org. Subject email: **ACTION_Quotation_Hand Washing station_JOGJA**

Award

The ACTION consortium shall award a Purchase Order to the lowest priced bidder whose quotation has been determined to be substantially compliant with other documents requested. If the tenderer's offer is selected, the consortium may ask the tenderers to submit additional



This project is funded by
the European Union



documents for approval like: product quality certificates, manufacturing license, country of origin, product brochures, etc.